



Rotary Air Blowers

RS (S, A, R)



Horizontal type — Works as it should for a wide variety of applications.

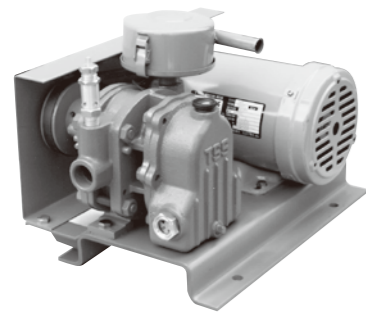

RSS
(Discharge Bore 20, 25, 32mm)

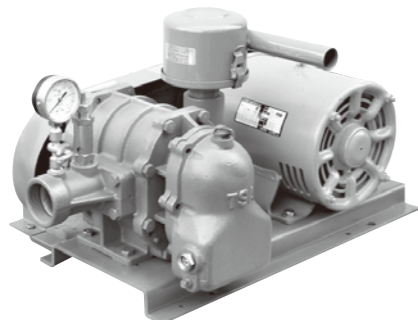

RSA
(Discharge Bore 40, 50, 65mm)

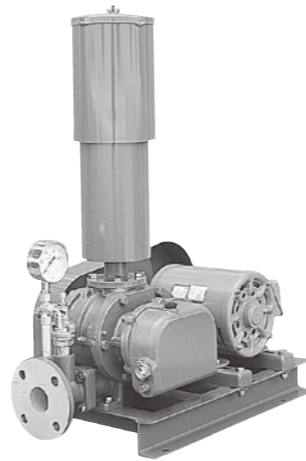

RSR
(Discharge Bore 50, 65, 80, 100, 125, 150mm)

Applications

- Aeration at water treatment facilities;
- Stirring of various waste liquids and sewage to prevent putrefaction and scum;
- Oxygen supply at aquariums and fish farms.

Virtues

- The rush of suction or discharge has been tamed resulting in greatly reduced impact noise and pulsation noise.
- Minimized operation noise, even and stable performance plus outstanding durability.
- Compact design for space economy and effortless maintenance services.

Structural Features

Innovative helical intake / outlet

Conventional blowers were designed to discharge the air from the casing in a gust. This caused violent impact and pulsation and resultant noise. Tsurumi blowers have helical structure at the intake and the outlet. This makes the air virtually pass through a gradually closing suction port or gradually opening discharge port. The result is remarkably reduced pulsation noise.

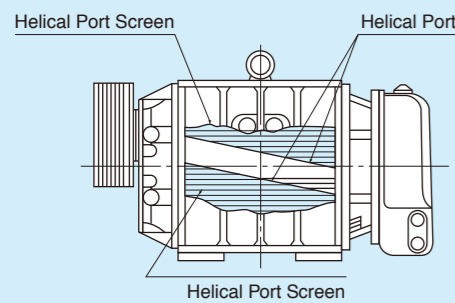

Special silencer and 3-lobe rotor

A specially prepared silencer absorbs a broad range of noise frequencies from low to high. The air flow rate and pressure characteristics have been greatly upgraded by the adoption of a 3-lobe rotor with each blade deliberately displaced as to thrust direction to avoid mutual contact.



Helical Port

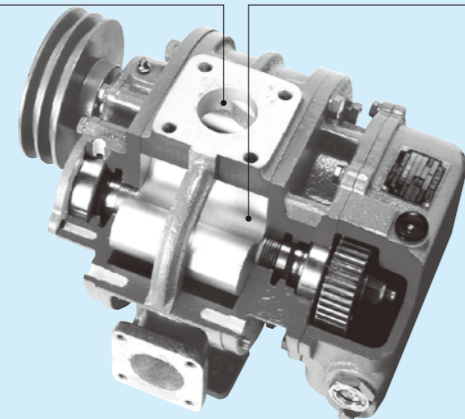
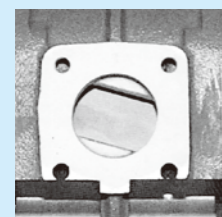

Rotor

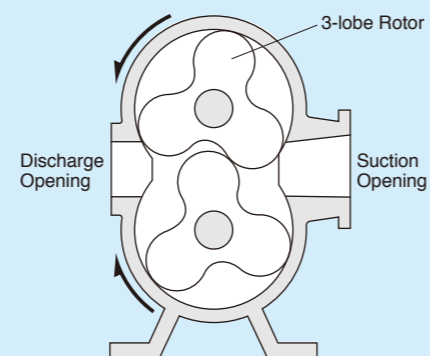

Major Components & Specifications

Item	Discharge bore (mm)											
	20	25	32	40	50	65	80	100	125	150		
Treating fluid	Type of fluid	Air										
	Fluid temperature	0~40°C										
Blower	Structure	Rotor	3-lobe rotor									
		Shaft seal	Labyrinth									
		Bearing	Shielded ball bearing									
	Materials	Rotor	Gray iron casting									
		Casing	Gray iron casting									
Shaft	Carbon steel											
Motor	Type, Pole	Drip-proof motor, 4-pole										
	Class of insulation	Class E										
	Phase	Single-phase (0.4kW only) Three-phase										
Discharge connection		RSS & RSA / Screw (ISO Rc-type) RSR / JIS 10K flange										

Standard Accessories

- Common base..... 1 pc.
- Suction silencer (with air filter)..... 1 set
- Safety valve..... 1 set
- Pressure gauge (RSA, RSR)..... 1 set
- Foundation bolts..... 1 set

Optional Accessories

- Discharge silencer
- Flexible joint
- Gate valve
- Check valve
- Rubber vibration isolator (with vibration-isolating base)
- Totally-enclosed, outdoor motor

Reference Drawing for Piping (Example)

RSS · RSA

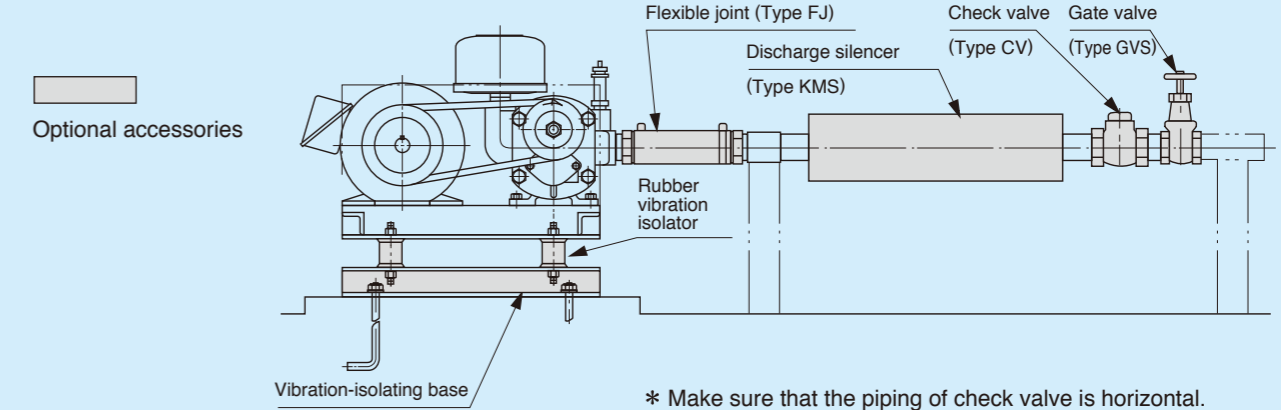

HOW TO USE THE SELECTION TABLE

Information about 50/60Hz Selection Tables

These tables indicate the relationships among blower models, bores, rpm, discharge pressure, actual air flow rates, and shaft power.

1. The amounts of air indicated in the tables represent suction amounts under the following standard suction conditions: temperature, 20°C; absolute pressure, 101.3kPa {1.033kgf / cm²}, relative humidity, 65%.
2. The amounts of air under reference suction conditions (temperature, 0°C; absolute pressure, 101.3kPa {1.033kgf / cm²}) can be converted into the amounts of air under the standard suction conditions by the formula below if the suction pressures are the same:

$$Q_s = Q_n \times \frac{273 + t_s}{273}$$

where

Q_s, amount of air (m³ / min) under standard suction conditions indicated on the Selection Tables;
Q_n, amount of air (m³ / min) under reference suction conditions;
Suction pressure is ambient pressure, 101.3kPa; t_s, suction temperature in °C.

3. To convert the amounts of air under discharge conditions into the amounts of air under the standard suction conditions indicated on the Selection Tables, use the following formula:

$$Q_s = Q_d \times \frac{101.3 + P_d}{101.3} \times \frac{273 + t_s}{273 + t_d}$$

where

Q_d, amount of air (m³ / min) under discharge conditions;
P_d, discharge pressure (kPa);
t_s, suction temperature in °C;
t_d, discharge temperature in °C.

4. Using the amount of air and the necessary discharge pressure obtained from the above mathematics, determine your blower model, bore, rpm, and shaft power in reference to the Selection Tables.
5. Your selectable range can be overlapped over several models. It is recommended that the one with a younger model number for cost economy, or with a larger model number for lower noise, be selected.
6. Motor output is identified by color on the Selection Tables. Select a suitable color motor from these tables.

Selection Table

Model (Discharge bore mm)	Speed (min ⁻¹)	Suction air volume at 20°C (Qs, m ³ /min) and required power (La, kW)																							
		9.8kPa		14.7kPa		19.6kPa		24.5kPa		29.4kPa		34.3kPa		39.2kPa		44.1kPa		49.0kPa		53.9kPa		58.8kPa			
		Qs	La	Qs	La	Qs	La	Qs	La	Qs	La	Qs	La	Qs	La	Qs	La	Qs	La	Qs	La	Qs	La		
RSR-50 (50)	1100	1.19	0.26	1.13	0.40	1.08	0.54	1.03	0.68	0.99	0.82	0.95	0.96	0.92	1.10	0.89	1.24	0.86	1.38	—	—	—	—		
	1230	1.36	0.36	1.30	0.51	1.25	0.66	1.20	0.81	1.16	0.96	1.12	1.11	1.08	1.26	1.05	1.41	1.02	1.56	0.99	1.71	—	—		
	1350	1.51	0.47	1.46	0.63	1.41	0.79	1.36	0.95	1.32	1.11	1.28	1.27	1.24	1.43	1.20	1.59	1.17	1.75	1.13	1.91	—	—		
	1470	1.68	0.63	1.63	0.79	1.59	0.95	1.54	1.11	1.50	1.28	1.46	1.44	1.43	1.60	1.39	1.76	1.35	1.93	1.32	2.09	1.29	2.26		
	1560	1.81	0.75	1.77	0.91	1.73	1.08	1.69	1.24	1.65	1.41	1.61	1.57	1.58	1.74	1.54	1.90	1.50	2.07	1.47	2.23	1.43	2.40		
	1660	1.93	0.80	1.89	0.98	1.85	1.16	1.81	1.33	1.77	1.51	1.73	1.69	1.69	1.87	1.65	2.05	1.61	2.23	1.58	2.40	1.54	2.58		
	1750	2.04	0.85	2.00	1.04	1.96	1.23	1.92	1.42	1.88	1.61	1.84	1.80	1.80	1.99	1.76	2.18	1.72	2.37	1.68	2.56	1.64	2.75		
	1850	2.17	0.99	2.13	1.18	2.09	1.37	2.05	1.57	2.01	1.76	1.97	1.95	1.93	2.14	1.89	2.34	1.85	2.53	1.81	2.71	1.77	2.91		
	1960	2.32	1.14	2.28	1.34	2.24	1.53	2.20	1.73	2.16	1.92	2.12	2.12	2.08	2.31	2.04	2.51	2.00	2.70	1.96	2.90	1.92	3.09		
	2120	2.52	1.41	2.47	1.62	2.42	1.82	2.38	2.03	2.33	2.23	2.29	2.44	2.24	2.64	2.20	2.85	2.16	3.05	2.12	3.26	2.08	3.46		
Corresponding motor output		0.75kW				1.5kW				2.2kW				3.7kW				—				—			
RSR-65 (65)	1110	1.67	0.63	1.58	0.80	1.50	0.97	1.43	1.14	1.37	1.31	1.32	1.48	1.27	1.65	1.22	1.82	1.17	1.99	—	—	—	—		
	1240	1.91	0.70	1.84	0.89	1.76	1.08	1.68	1.27	1.62	1.46	1.56	1.65	1.51	1.84	1.46	2.03	1.41	2.22	1.36	2.41	—	—		
	1360	2.14	0.80	2.07	1.01	2.00	1.22	1.93	1.43	1.87	1.64	1.81	1.85	1.76	2.06	1.70	2.27	1.65	2.48	1.60	2.69	—	—		
	1460	2.35	0.88	2.27	1.11	2.20	1.33	2.13	1.55	2.07	1.78	2.01	2.00	1.96	2.22	1.90	2.45	1.85	2.67	1.80	2.90	1.76	3.13		
	1550	2.54	0.96	2.46	1.20	2.39	1.43	2.32	1.67	2.25	1.97	2.19	2.14	2.14	2.37	2.08	2.61	2.03	2.84	1.98	3.08	1.94	3.31		
	1670	2.75	1.05	2.68	1.31	2.62	1.56	2.56	1.82	2.49	2.07	2.43	2.33	2.38	2.58	2.33	2.83	2.28	3.08	2.23	3.34	2.19	3.59		
	1770	2.94	1.13	2.88	1.40	2.82	1.67	2.76	1.94	2.70	2.21	2.64	2.48	2.59	2.75	2.54	3.02	2.49	3.29	2.45	3.56	2.41	3.83		
	1860	3.13	1.24	3.07	1.52	3.00	1.80	2.94	2.08	2.88	2.36	2.82	2.65	2.76	2.93	2.71	3.22	2.66	3.50	2.61	3.78	2.57	4.07		
	1980	3.39	1.38	3.32	1.62	3.25	1.98	3.18	2.28	3.12	2.57	3.06	2.87	3.00	3.18	2.94	3.48	2.89	3.78	2.84	4.08	2.80	4.38		
	2150	3.65	1.60	3.58	1.93	3.52	2.25	3.46	2.58	3.40	2.90	3.34	3.23	3.28	3.55	3.22	3.88	3.17	4.20	3.12	4.53	3.08	4.85		
Corresponding motor output		1.5kW				2.2kW				3.7kW				5.5kW				—							
RSR-80 (80)	1130	2.99	0.77	2.93	1.10	2.86	1.43	2.80	1.76	2.73	2.09	2.67	2.42	2.61	2.75	2.55	3.08	2.50	3.41	2.45	3.74	2.41	4.07		
	1240	3.36	0.89	3.29	1.28	3.22	1.63	3.16	1.99	3.09	2.34	3.03	2.70	2.97	3.05	2.92	3.41	2.86	3.76	2.81	4.12	2.76	4.47		
	1300	3.56	1.03	3.49	1.40	3.42	1.77	3.36	2.14	3.29	2.50	3.23	2.88	3.17	3.24	3.12	3.62	3.06	3.98	3.01	4.35	2.96	4.72		
	1370	3.80	1.16	3.74	1.55	3.67	1.93	3.60	2.32	3.53	2.70	3.47	3.09	3.41	3.47	3.36	3.86	3.30	4.24	3.25	4.63	3.20	5.01		
	1470	4.12	1.30	4.04	1.72	3.97	2.13	3.90	2.55	3.83	2.96	3.77	3.38	3.71	3.79	3.66	4.21	3.60	4.62	3.55	5.04	3.50	5.45		
	1570	4.42	1.51	4.35	1.94	4.28	2.37	4.22	2.80	4.15	3.23	4.10	3.66	4.04	4.09	3.99	4.52	3.93	4.95	3.89	5.38	3.84	5.81		
	1660	4.72	1.69	4.65	2.14	4.58	2.59	4.52	3.04	4.45	3.49	4.40	3.94	4.34	4.39	4.29	4.84	4.23	5.29	4.18	5.74	4.13	6.19		
	1750	5.04	1.90	4.96	2.36	4.88	2.82	4.81	3.28	4.74	3.74	4.69	4.20	4.63	4.66	4.58	5.12	4.52	5.58	4.48	6.04	4.44	6.50		
	1840	5.31	2.07	5.24	2.56	5.17	3.05	5.11	3.54	5.07	4.03	4.99	4.52	4.93	5.01	4.88	5.50	4.82	5.99	4.78	6.48	4.73	6.97		
	1930	5.61	2.27	5.54	2.78	5.46	3.29	5.40	3.80	5.33	4.31	5.28	4.82	5.22	5.33	5.17	5.84	5.11	6.35	5.06	6.86	—	—		
Corresponding motor output		2.2kW				3.7kW				5.5kW				7.5kW				—							
RSR-100 (100)	1070	4.51	1.20	4.37	1.70	4.22	2.20	4.09	2.70	3.96	3.20	3.83	3.70	3.75	4.20	3.67	4.70	3.58	5.20	3.50	5.70	3.42	6.20		
	1160	5.00	1.42	4.85	1.95	4.69	2.49	4.56	3.03	4.43	3.56	4.33	4.10	4.23	4.64	4.15	5.17	4.06	5.71	3.98	6.25	3.90	6.78		
	1240	5.45	1.56	5.29	2.13	5.12	2.70	4.99	3.27	4.86	3.84	4.76	4.41	4.66	4.98	4.57	5.55	4.48	6.12	4.40	6.69	4.32	7.26		
	1320	5.97	1.64	5.82	2.27	5.66	2.89	5.54	3.52	5.41	4.14	5.31	4.77	5.21	5.39	5.12	6.02	5.02	6.64	4.94	7.27	4.86	7.89		
	1480	6.67	1.77	6.53	2.47	6.39	3.13	6.28	3.86	6.17	4.49	6.08	5.25	5.99	5.85	5.92	6.64	5.84	7.21	5.77	8.03	5.70	8.57		
	1580	7.14	1.92	7.01	2.66	6.88	3.37	6.77	4.13	6.66	4.83	6.58	5.60	6.49	6.28	6.42	7.07	6.34	7.74	6.27	8.54	6.20	9.19		
	1700	7.71	2.09	7.59	2.88	7.47	3.66	7.37	4.45	7.26	5.23	7.19	6.02	7.11	6.80	7.03	7.59	6.94	8.37	6.88	9.16	6.82	9.93		
	1790	8.12	2.24	8.01	3.12	7.90	3.89	7.80	4.71	7.70	5.53	7.63	6.36	7.55	7.13	7.48	8.00	7.40	8.82	7.33	9.65	7.26	10.46		
	1890	8.58	2.41	8.48	3.28	8.38	4.14	8.29	5.01	8.19	5.87	8.12	6.74	8.05	7.60	7.98	8.47	7.90	9.33	7.83	10.20	7.76	11.06		
	2010	9.19	2.56	9.09	3.49	9.00	4.41	8.91	5.34	8.82	6.26	8.76	7.19	8.70	8.11	8.64	9.04	8.58	9.96	8.53	10.89	8.47	11.81		
Corresponding motor output		3.7kW				5.5kW				7.5kW				11kW				15kW							
RSR-125 (125)	980	6.41	1.80	6.26	2.46	6.12	3.12	5.98	3.78	5.86	4.44	5.74	5.10	5.63	5.76	5.52	6.42	5.43	7.08	5.34	7.74	5.26	8.40		
	1050	6.93	2.10	6.77	2.79	6.63	3.48	6.50	4.17	6.37	4.86	6.25	5.55	6.14	6.24	6.04	6.93	5.94	7.62	5.86	8.31	5.78	9.00		
	1200	7.94	2.70	7.79	3.48	7.65	4.25	7.53	5.03	7.40	5.80	7.29	6.58	7.18	7.35	7.07	8.13	6.98	8.90	6.89	9.68	6.81	10.45		
	1310	8.70	3.10	8.58	3.95	8.47	4.80	8.37	5.65	8.27	6.50	8.17	7.35	8.07	8.20	7.98	9.05	7.89	9.90	7.81	10.75	7.73	11.60		
	1410	9.40	3.39	9.28	4.31	9.17	5.22	9.06	6.13	8.96	7.04	8.86	7.95	8.76	8.86	8.67	9.77	8.58	10.68	8.50	11.59	8.42	12.50		
	1470	9.83	3.69	9.71	4.64	9.60	5.59	9.50	6.53	9.40	7.48	9.30	8.42	9.21	9.36	9.12	10.31	9.03	11.25	8.95	12.19	8.88	13.14		
	1550	10.44	3.90	10.31	4.90	10.19	5.90	10.07	6.90	9.96	7.90	9.86	8.90	9.76	9.90	9.67	10.90	9.58	11.90	9.50	12.90	9.43	13.90		
	1650	11.13	4.40	11.00	5.48	10.87	6.56	10.76	7.64	10.65	8.72	10.55	9.80	10.45	10.88	10.36	11.96	10.28	13.04	10.20	14.12	10.14	15.20		
	1770	11.92	4.90	11.79	6.07	11.68	7.14	11.57	8.26	11.47	9.38	11.37	10.50	11.28	11.62	11.20	12.74	11.13	13.86	11.06	14.98	11.00	16.10		
	1880	12.63	5.40	12.50	6.58	12.39	7.76	12.28	8.94	12.18	10.12	12.08	11.30	11.99	12.48	11.91	13.66	11.83	14.84	11.76	16.02	11.70	17.20		
Corresponding motor output		5.5kW				7.5kW				11kW				15kW				18.5kW							
RSR-150 (150)	810	12.90	2.91	12.65	3.75	12.42	4.59	12.21	5.54	12.02	7.50	11.85	8.89	11.69	10.27	11.53	11.60	11.38	12.93	11.25	14.06	11.14	15.19		
	870	14.13	3.13	13.84	4.51	13.58	5.90	13.33	7.12	13.10	8.67	12.89	10.05	12.69	11.43	12.51	12.82	12.34	14.20	12.19	15.59	12.05	16.97		
	990	15.92	3.34	15.67	4.90	15.44	6.46	15.22	8.02	15.0															

Pumps & Other Equipment For Water Treatment

Tsurumi provides you with an extensive lineup of models to suit your specific needs.

SEWAGE PUMP

B series



Discharge Bore : 50 - 800 mm
Motor Output : 0.4 - 110 kW

RESIN-MADE SEWAGE PUMP

PU series



Discharge Bore : 40 - 80 mm
Motor Output : 0.15 - 3.7 kW

AERATOR

TRN series



Air-Inlet Bore : 32 - 150 mm
Motor Output : 0.75 - 40 kW

JET AERATOR

BER series



Air-Inlet Bore : 25 - 50 mm
Motor Output : 0.75 - 5.5 kW

FLOATING SCUM SKIMMER

FSP series



Discharge Bore : 50 mm
Motor Output : 0.4 - 0.75 kW

FLOATING DECANTER

FHP series



Discharge Bore : 40 - 80 mm
Motor Output : 0.25 - 1.5 kW

We reserve the right to change the specifications and designs for improvement without prior notice.

TSURUMI
MANUFACTURING CO., LTD.
www.tsurumi-global.com

Your Dealer